

THROUGH-BEAM PHOTOCELL FB 15

The through-beam photocell series **Maps-FB15** consists of two modules, a transmitter and a receiver which operate using a modulated beam of infrared light pulse. It can work at a distance of 1m to 15m between transmitter and receiver, in any type of ambient light, even sunlight without any previous setting.

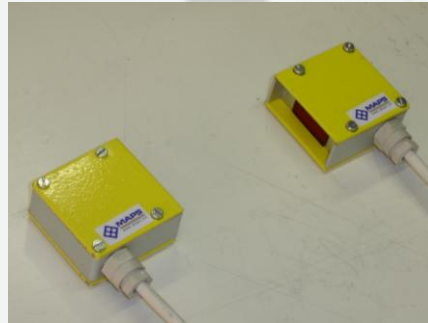

Main Characteristics:

- Power 12VDC to 30VDC (reverse polarity protection) / 75mA
- Output Relay potential free (Vmax AC 125/250 2A (FB-15C)). Two independent contacts: COM / NO / NC + COM / NO / NC.
- Open Collector Output (Vmax 45V 250mA (FB-15T)).
- Response time lower than 5ms.
- Immunity to sunlight.
- Detection distance between 1 and 15m.
- Led indicator at receiver.
- Protection grade: IP64.
- Working Temperature: -20°C to 65°C
- Accessories: Support that allows easy alignment of the modules.

Applications:

- Access control, opening / closing of automatic doors, opening / closing of security barriers, objects detection / counting, lighting, security, alarms ,etc.

The equipment is supplied with a 1.5m cable (other lengths on request).

Maps Informàtica Industrial develops control systems for industrial environments from 1973.

Transmitter and receiver Dimensions

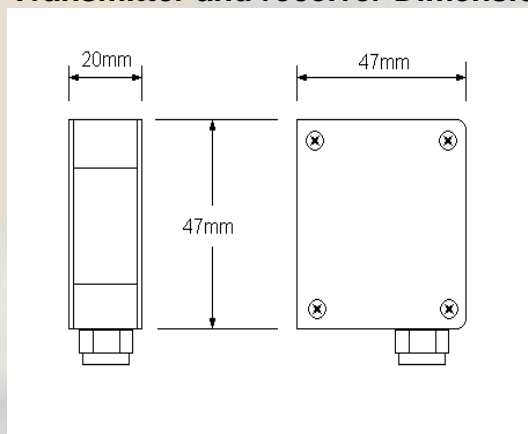

Auxiliary Support

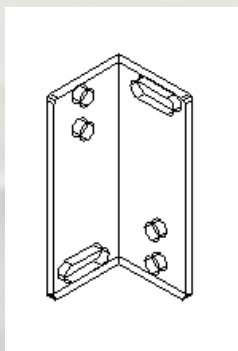

MAPS informàtica industrial
C/ La Costa 69 bis
08023 Barcelona
Tel: 93 2121598
Fax: 93 4177843
maps@maps.es